



SPARE PARTS EXPLODED VIEW
INSTANTANEOUS GAS WATER HEATERS

Model
FAST

R8218500-01 - 27/01/2020

FAST

Instantaneous Gas Water Heaters

1	3632710	FAST 10L NG	01-2020	-
Col	Reference	Model type	Begin	End

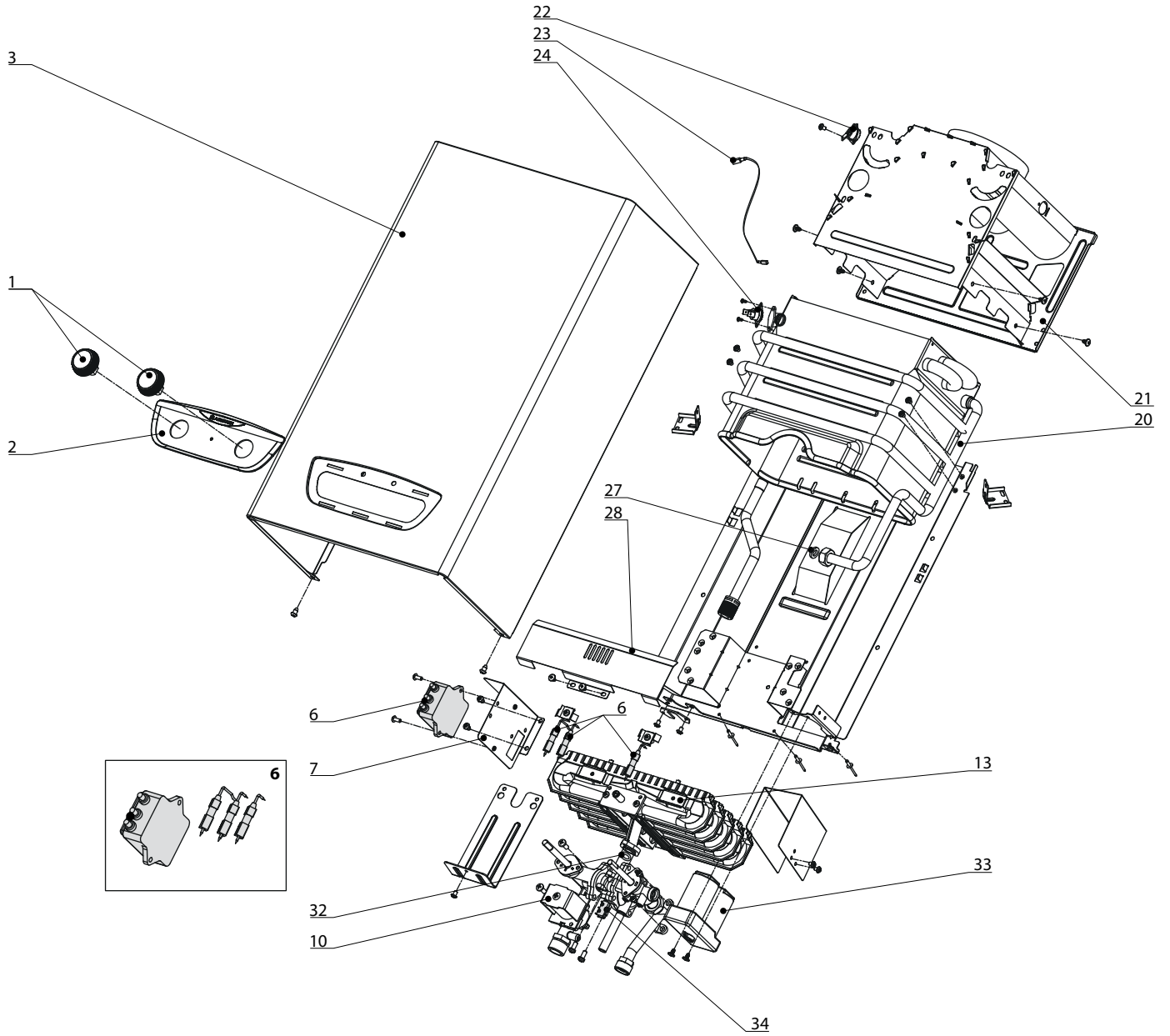

LIST OF THE ABBREVIATIONS

HW	: Hot water.
CW	: Cold water.
C	: Ceramic resistance (normal heating).
Ca	: Ceramic resistance (accelerated heating)
TP	: Immersion heater.
1F	: With fittings.
2F	: Without fittings.
3F	: With fittings and another outlet connection.
AMI	: With mixing valve.
SMI	: Without mixing valve.
PUISS	: Power of th appliance.
PN	: Appliance with normal pression.
LP	: Appliance with low pression.
PV	: Appliance with variable power.
PF	: Appliance with fixed power.

IDENTIFICATION PLATE

SERIAL NUMBER

10 Characters :	04 05 125 011		
		Sequential number	
		Manufacturing day	
		Year of manufacture	
11 Characters :	1 95 065004 - 31		
Month of manufacture :		Technical number of the appliance	
from 1 to 9 → Jan. to Sep.,		Sequential number	
O → Oct., N → Nov.,		Year of manufacture	
D → Dec.			
19 Characters :	08 05 0013199 900640031		
Year of manufacture		Product reference	
Month of manufacture		Sequential number	
20 Characters :	3675007 XX 2 07 070 00315		
Product reference		Sequential number	
Millenium of manufacture		Manufacturing day	
		Year of manufacture	
21 Characters :	3675007 XX 07 070 0000315		
Product reference		Sequential number	
Year of manufacture		Manufacturing day	